

Standalone Access Controller and Reader M3

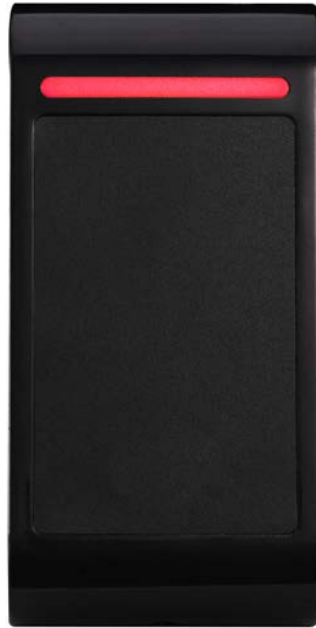

1 Description& Features:

1.1 Description:

M2 is a waterproof standalone access control, reading EM&HID card, it uses advanced Microprocessor, with high-capacity flash memory for 10000 users. Users can be added and deleted via management card with this device, very simple to operate. The infrared remote control make the device not only have alarm, protection, two units interlocked, anti-passback function but also can make two units interlocked, add and delete the user on the remote control key directly.

Besides, it has low power consumption design, anti-theft alarm, door release button ect. , all these make it convenient, safe and reliable.

1.2 Features:

Feature	Description
Waterproof Design	Rainproof, moistureproof , durable
Ultralow power consumption	Longer life span, more stable performance
Large capacity	10000 card users
wiegand reader	Can used as wiegand 26 output reader
Connect external reader	Can connect EM/IC/HIDwiegand 26 output reader
two units interlocked	two units can be interlocked online
Anti-passback	Single door or two doors anti-passback

2 Installation, wiring, diagram

2.1 Installation:

- 2.1.1 Drill the holes, according to the distance and the demension on the back cover, or install the distributing box.
- 2.1.2 Thread the cable through the cable hole, connect wire needed, wrapped Unused wire with insulating tape in case of short circuit
- 2.1.3 Fix the back cover on the wall with special screw
- 2.1.4 Fix the front cover to the back cover with the screws

2.2 Wiring

No.	Marks	Color	Description
-----	-------	-------	-------------

1	RESET	Pink	RESET
2	GND	Light blue	GND
3	D0	Green	Wiegand output D0
4	D1	White	Wiegand output D1
5	ALARM-	Grey	Alarm
6	OPEN	Yellow	Exit button
7	D_IN	Brown	Door contact switch
8	+12V	Red	+12V Input
9	GND	Black	GND
10	NO	Blue	Relay NO end
11	COM	Purple	Relay Com
12	NC	Orange	Relay NC end

Note: Please carefully check all of wires and installing front panel, then power on.

2.4 Diagram

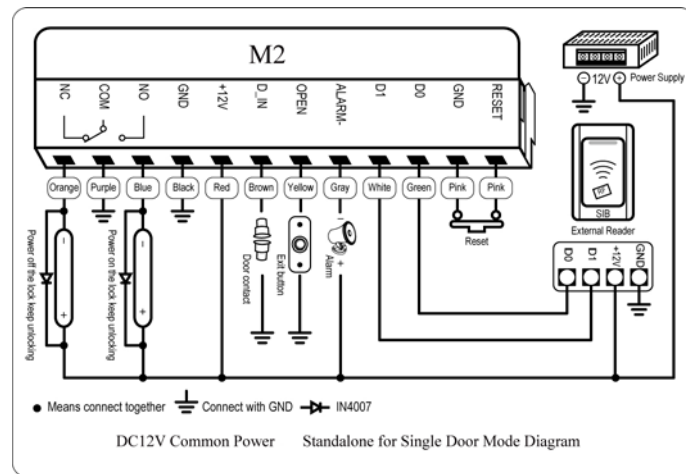

DC12V Common power Standalone for Single Door Diagram

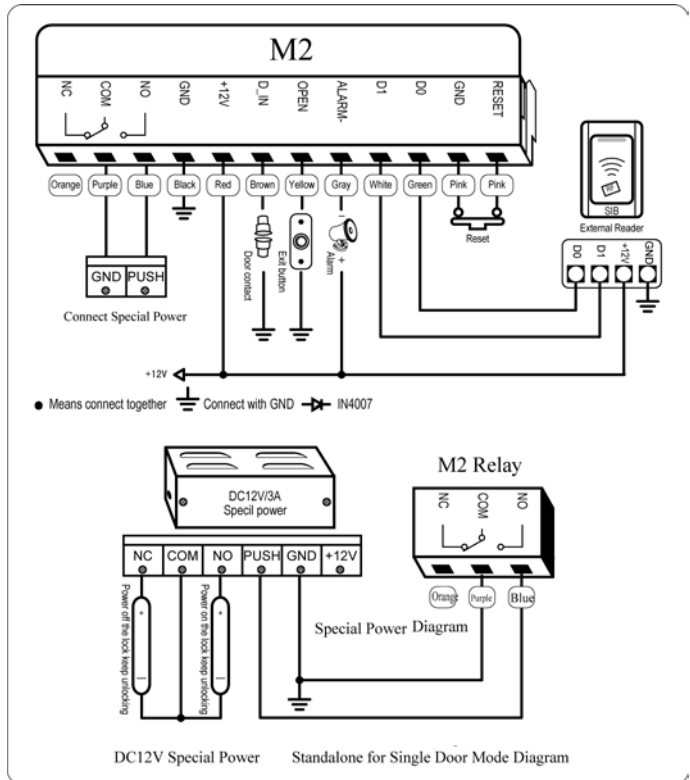

DC12V Special Power Standalone for Single Door Diagram

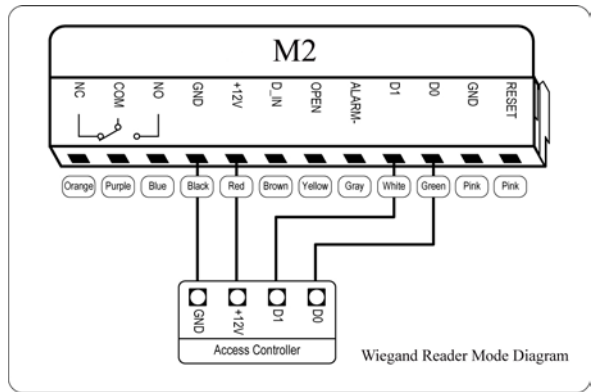

Wiegand Reader Diagram

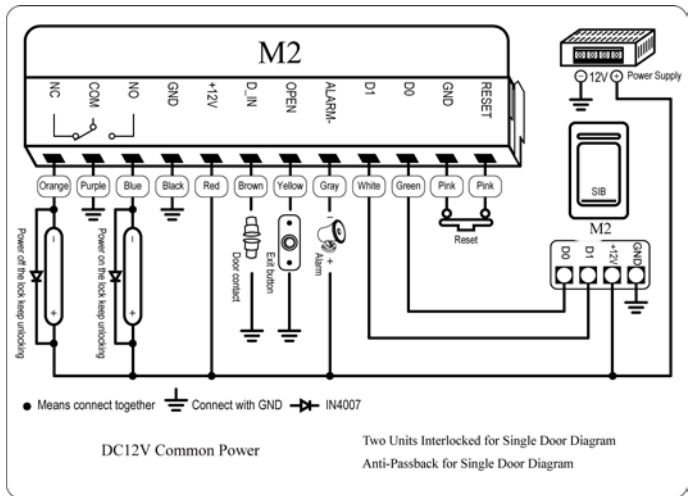

DC12V Common Power Two Units Interlocked for Single Door Diagram Anti-Passback for Single Door Diagram

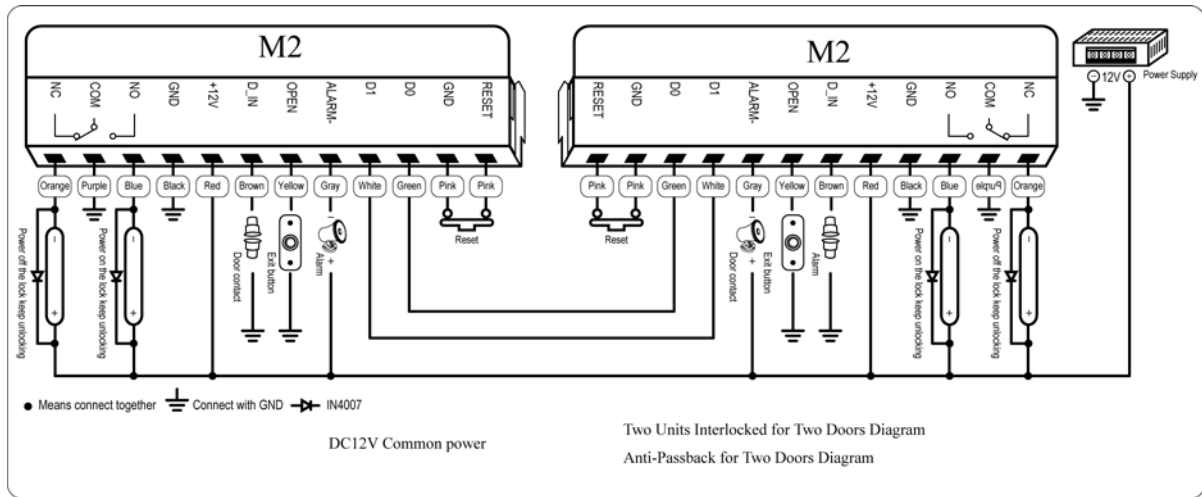

DC12V Common Power Two Units Interlocked for Two Doors Diagram
Anti-Passback for Two Doors Diagram

3 Factory Reset and Set management card

Press initialized button, then power on, release after sound “didi...”. When indication LED turns green, it means you can set two management cards now, read the first card as manager add card, the second card as manager delete card, then LED turns red flash, after this, this device can work ,resetting to factory default.

Note: Reset factory default wont delete user cards, If you present the same card when second read, the device will sound error reminding “didi” , then you can continue present another card. If no operations within 10seconds, the device will enter working mode automatically , parameter reset to factory default.

4 Admin setting on keypad

Entering admin operating mode:

Press factory default:999999

Note: All the below operations need be under programming mode.

4.1 Change the master code:

Press

Note: Master Code length:6~8 digits

4.2 Add users by remote control:

4.2.1 Read card to add user:

Press ...

4.2.2 Use ID Number to add user:

Press

Note: 1.Card number must be 8 or 10 digits, if the card number is less than 8 or 10 digits, input 0 before the card number

2. press confirm, press last finish, press exit.

4.2.3 Add consecutive number card.:

press

Add consecutive number cards users, card quantity 1-9999, green fast flash.

4.3 Delete users via remote:

4.3.1 Read card to delete user:

press

4.3.2 Use card NO. to delete user:

press

4.3.3 Delete all users:

press 。

Note: This operation will delete all users, but admin card wont be deleted

4.4 Safe mode setting:

4.4.1 Normal mode (factory default) :

press 。

4.4.2 Dead mode:

press 。

read invalid cards 10 times continuously within 10minutes, the device be dead for 10 minutes

4.4.3 Alarm mode:

press 。

read invalid cards 10times continuously within 10minutes, Both external alarm and built-in alarm sound.

4.5 Door open time setting:

press 。

Note: range“0~99seconds”, 0mS equates 50mS。

4.6 Alarm time setting:

press 。

Note: range“0~3minutes”, factory default 1minute。

4.7 Red light mode setting:

4.7.1 Static disable mode:

press 。

4.7.2 Static normal mode (factory default) :

press 。

4.8 Interlock setting:

4.8.1 Close interlock (factory default) :

press 。

4.8.2 Open interlock:

press 。

4.9 Anti-passback mode setting:

4.9.1 Disable anti-passback (factory default) :

press 。

4.9.2 Enable anti-passback host mode:

press 。

4.9.3 Enable anti-passback subsidiary mode:

Press 。

Note: Details will be illustrated in Advanced Application below.

5 management card operation:

5.1 Add user:

Press ... , finally exit.

5.2 Delete user:

Press ... , finally exit.

6 User open door operation

, read valid user card, door will be open, but management card cant open the door.

7 Remove alarm operation

7.1 External alarm and built-in alarm both sound

Read **user card** , **management card** or input **admin pin #** , alarm will be removed.

7.2 Inside buzzer alarm after door close

Close door or press **user card** , **management card** or input **admin password #** , alarm will be removed.

8 Sound and Light Indication

Operation	LED Color	Buzzer
Initialization	Orange	didi
Static	Red Flash	
Valid press key		di—
Enter programme	Red	di—
Setting	Orange	di
Exit	Red Flash	di—
Operation Failed		didi
Lock open	Green	di—
Alarm	Red Quick Flash	Alarm
Add sequential No. card	Green Quick Flash	

9 Specifications

Operating Voltage	DC12V±10%
Static	<30mA
Card Reading Distance	5~8cm
Operating Temperature	-45~60℃
Operating Humidity	20%~98%
Lock Output Load	2A
Alarm Output Load	2A
management card	2pcs

10 Packing List

Name	Model/Spec	Quantity
Access Control	M2	1
Infrared Remote Control		1
Manager Add Card		1
Manager Delete Card		1
Manual	M2	1
Self tapping screws	Φ3.5*27mm	2
Screw driver	Star	1

NOTE: Advanced Application

1 two units for single door

Install one at indoor and the other at outdoor, indoor one as controller , outdoor one as reader

Compare two units for single door with one unit for single door:

1.1 Add users on both unit, both indoor user data and outdoor data can be shared, users can be up to 20000.

1.2 The setting of the two device must be the same, when admin pin setting is different, outdoor unit can't open the door with saved users data.

2 Two units interlocked for two doors

Install two controllers for two doors, control two locks separately , set interlocked for two units , open door contact . The other door is locked when door is open. The other door can be open after close the door. The device can't control another electric lock, data can't share between different units. This function mainly apply for bank, prison etc.

3 Anti-passback for Single door

Install a common reader outdoor (or use this device without any card No. for reader) . Install this device outdoor and set it as anti-passback host mode. In this case, the two units consist of an anti-passback system for single door, mainly apply to controlling enter and exit for single door. Details operation is as below:

3.1 Set necessary functions and add user card on the host device.

3.2 Users can only present the card on the external reader to enter, and then present the card on the host device to exit, then, present card on the external reader to enter, do it like this, enter legally, and then exit legally. Users cant enter or exit at continuous 2 times.

4 Anti-passback for two doors

Install one device on Door 1 under anti-passback subsidiary mode, Install one device on Door 2 under anti-passback host mode, in this case, the two units consist of anti-passback for two doors, mainly apply for one-way in and out for double doors like parking. Functions as follows:

4.1 Set necessary functions and add user card on the host device.

4.2 Users can only present the card on the subsidiary device to enter, and then present the card on the host device to exit, then, present card on subsidiary device to enter, do it like this, enter legally, and then exit legally. Users cant enter or exit at continuous 2 times.