

INSTALLATION MANUAL

Product Image

Model:YAD-200SW(PUSH)

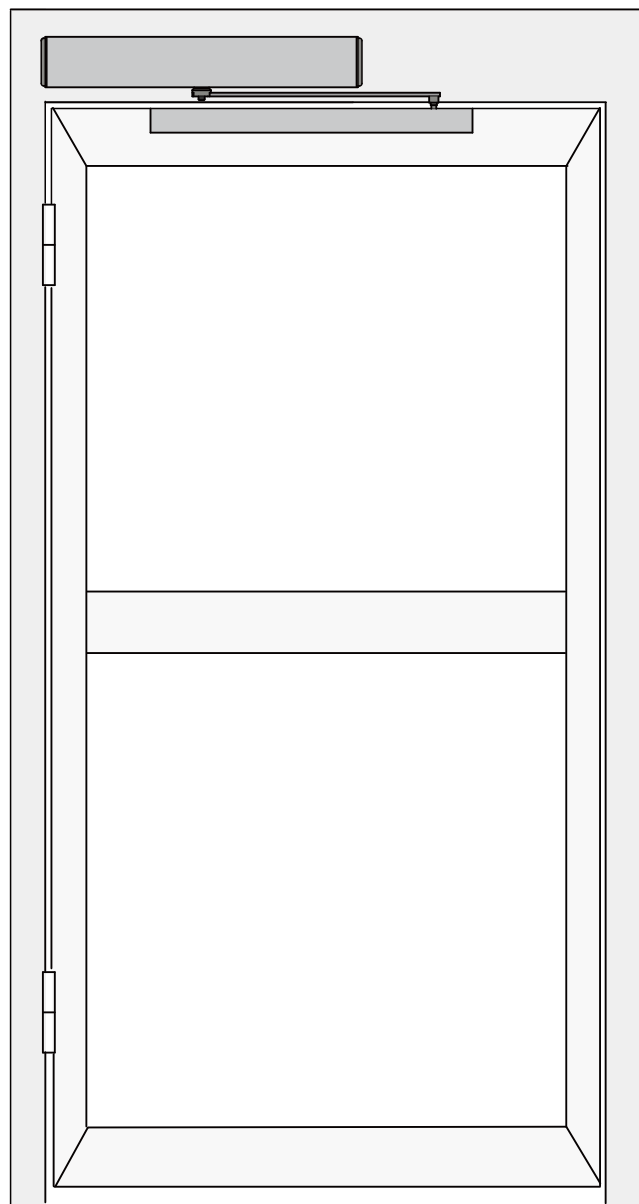

INSTALLATION MANUAL

Contents

1	Technical Parameters	2
2	Components	3
3	Installation	4
3.1	Installation Example	4
3.2	Installation of base plate	5
3.3	Installation of pull arm	6
3.4	Installation of push arm	7
3.5	Installation of operation system	8
3.6	Installation of cover	9
3.7	Connection of operation system and pull arm	9
3.8	Connection of operation system and push arm	10
4	Electrical connection	11-15
5	Parameters adjustment	16

Technical Parameters

Voltage: 110 ~220V ±10%
 Power consumption: 50W
 Opening time: 3-7s/90°
 Hold open time: t_h 1~30s adjustable
 Max. door frame depth: 450mm
 Door width: Min. 660mm / Max. 1200mm
 Max. opening angle: 120°
 Environment Temperature: -20°C~+50°C
 Protection class: IP12D
 Product weight: 6.5Kg
 Dimension: L540xH95xW82mm

mm=Door width
 kg=Door weight

 Suitable range

 Range limit

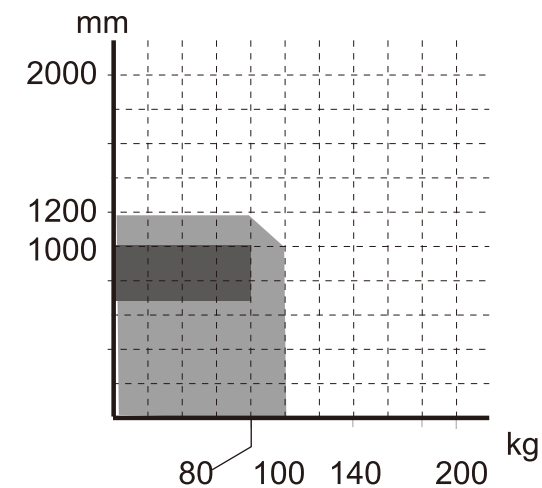

INSTALLATION MANUAL

Components

hole for power cable

hole for sensor cable



base plate

power connector

motor

controller

operator

output axis

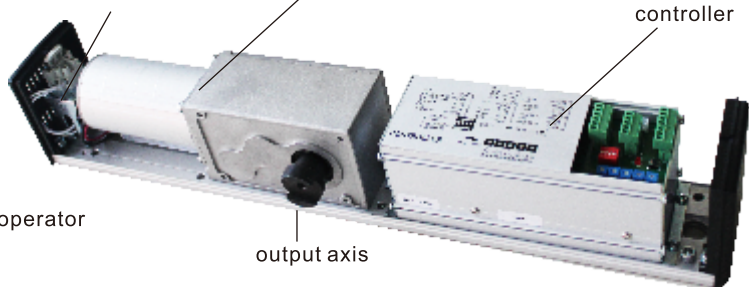

cover



pull arm(alternative)
Inward opening



push arm(alternative)
Outward opening

INSTALLATION MANUAL

Installation

3.1 Installation example

Choose pull arm: door leaf open toward inside {operator is inside}

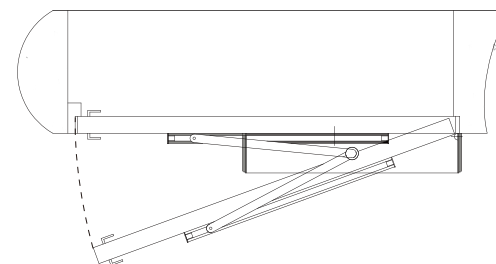
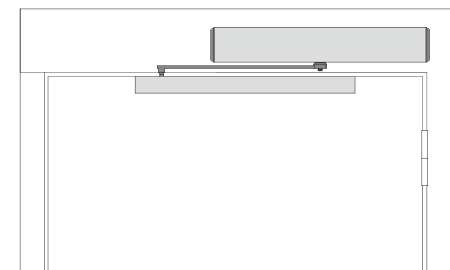

Choose push arm: door leaf open toward outside (operator is inside)

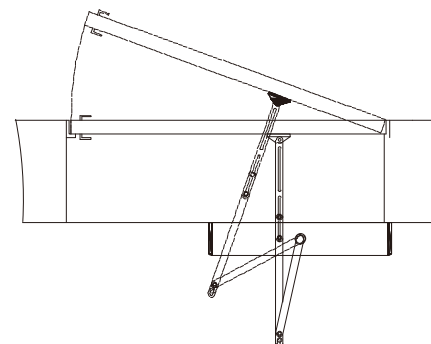
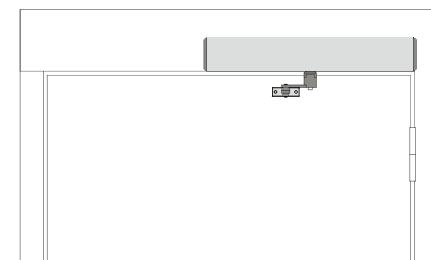

INSTALLATION MANUAL

3.2 Installation of base plate

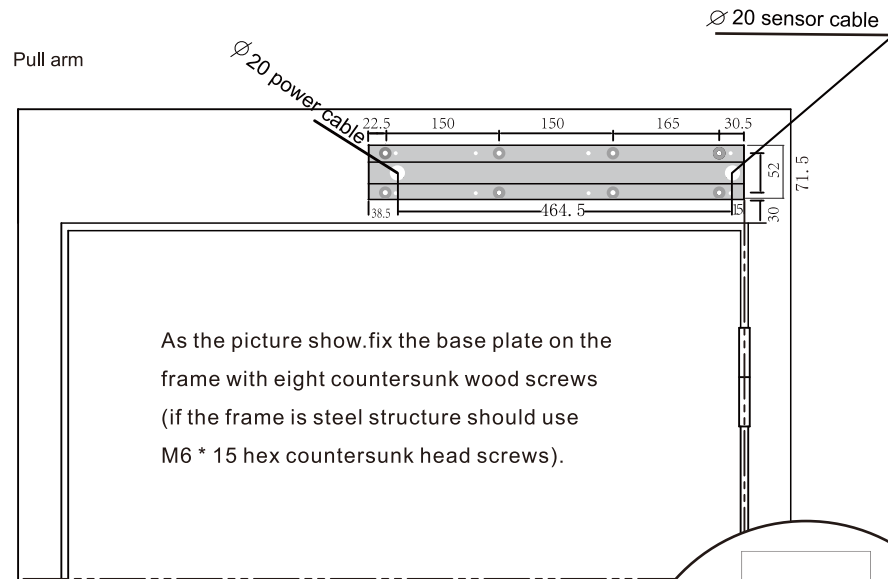

As the picture show,fix the base plate on the frame with eight countersunk wood screws (if the frame is steel structure should use M6 * 15 hex countersunk head screws).

At door right

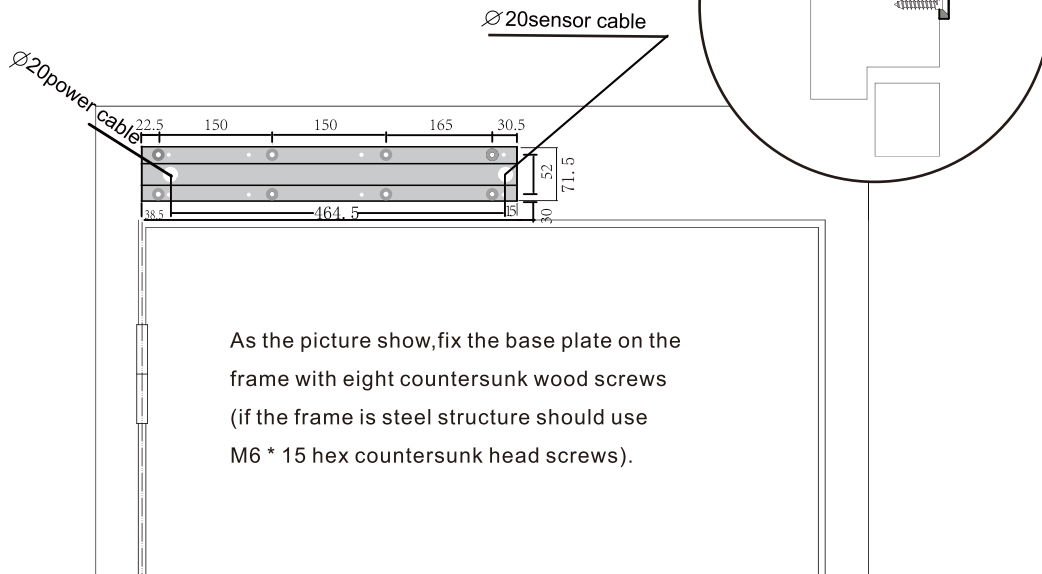

As the picture show,fix the base plate on the frame with eight countersunk wood screws (if the frame is steel structure should use M6 * 15 hex countersunk head screws).

At door left

INSTALLATION MANUAL

3.3 Pull arm

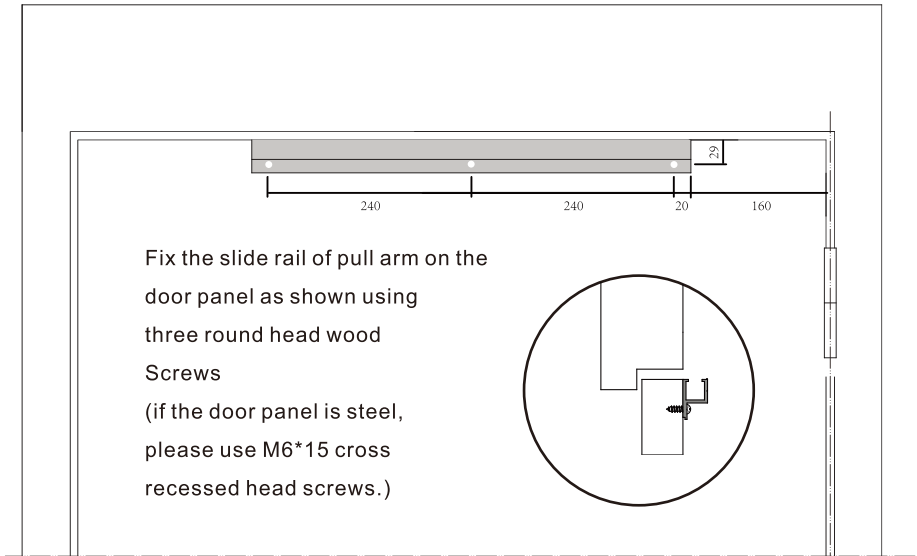

Fix the slide rail of pull arm on the door panel as shown using three round head wood Screws (if the door panel is steel, please use M6*15 cross recessed head screws.)

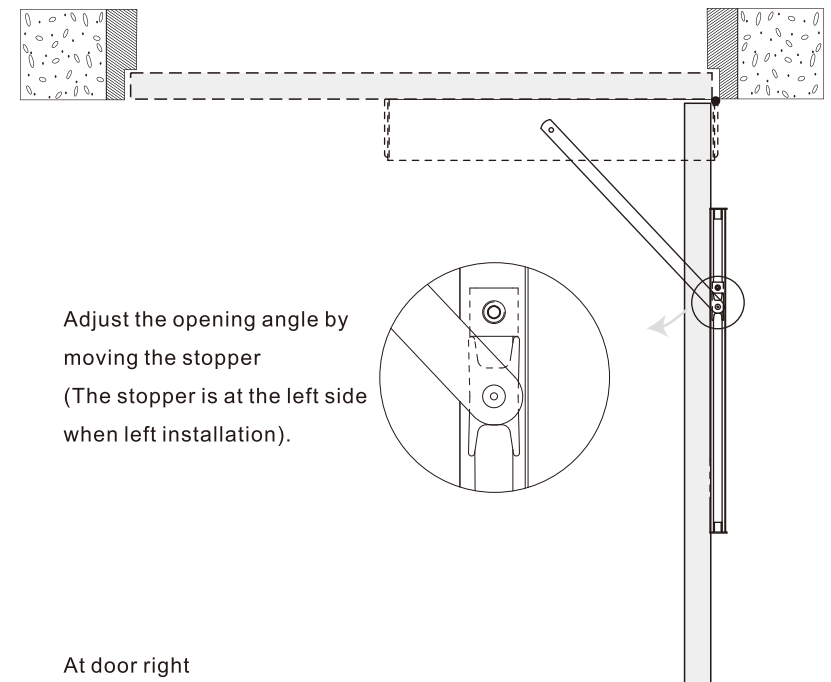

Adjust the opening angle by moving the stopper (The stopper is at the left side when left installation).

At door right

INSTALLATION MANUAL

3.4 Pull arm

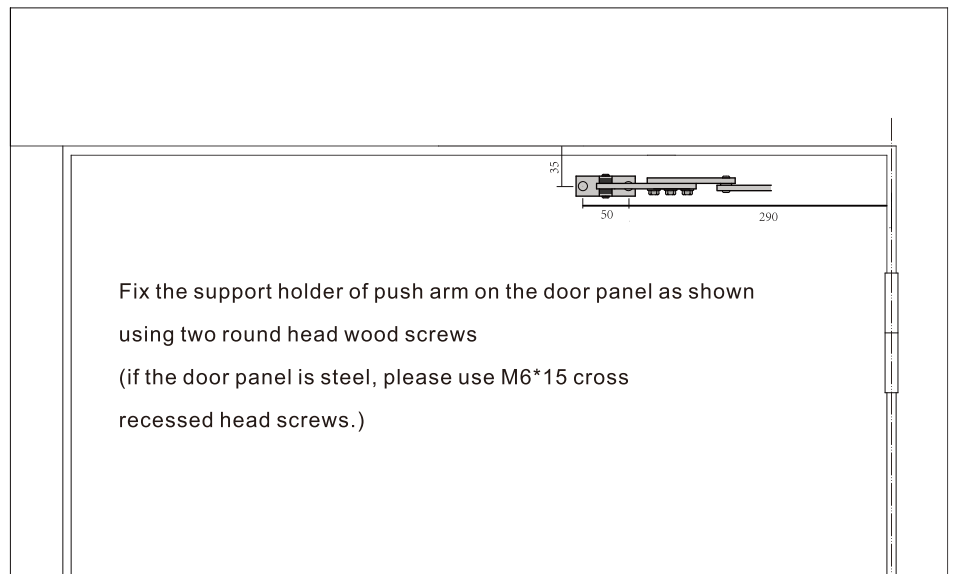

Fix the support holder of push arm on the door panel as shown using two round head wood screws (if the door panel is steel, please use M6*15 cross recessed head screws.)

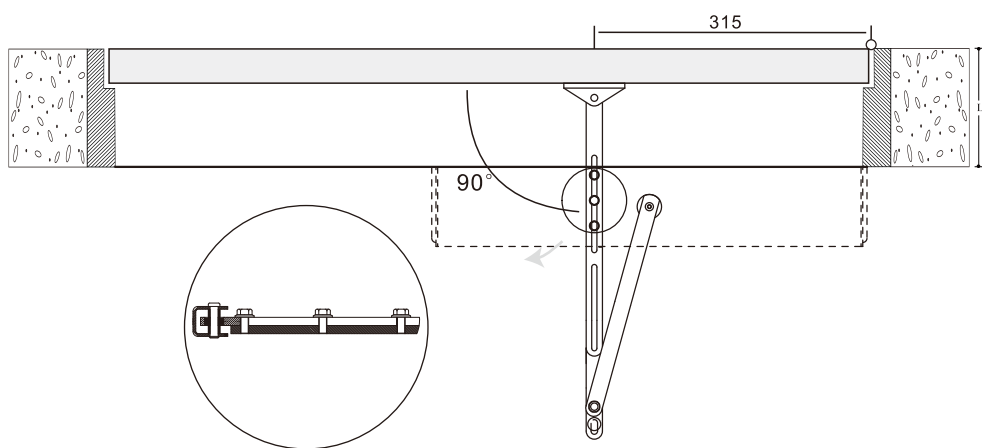

Loosen this three bolts and adjust the push arm length according to the door depth(L) until the angle between the push arm and door panel is 90°.

At door right

INSTALLATION MANUAL

3.4 Pull arm

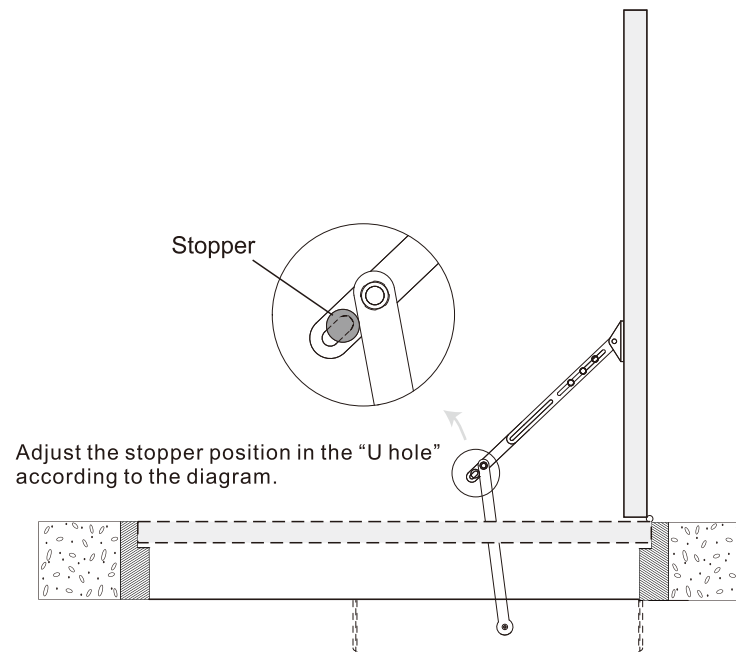

Adjust the stopper position in the "U hole" according to the diagram.

3.5 operation system

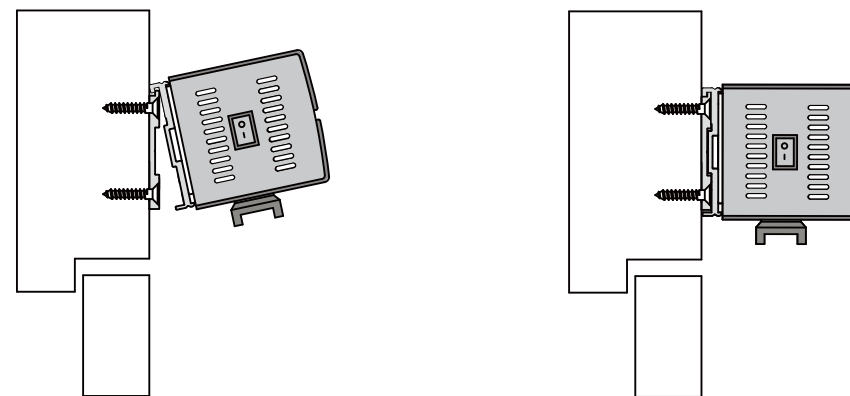

Hook the operation system on the finished base plate as shown, fix it with eight hexagon socket head screws.

INSTALLATION MANUAL

3.6 Cover

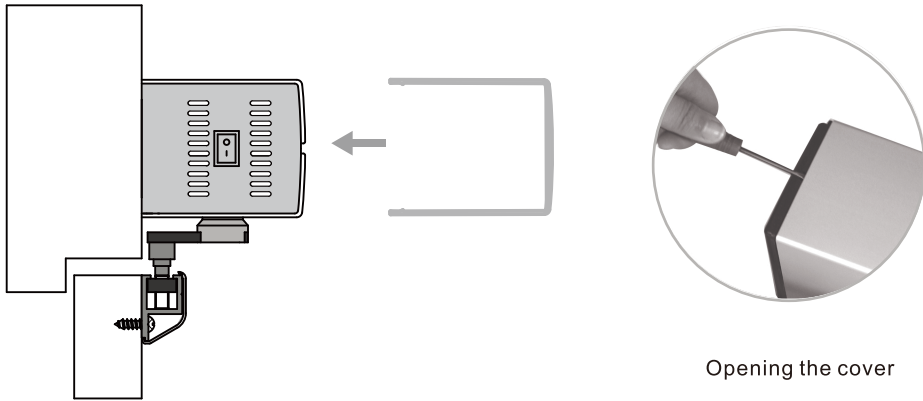

3.7 Connect the operation system and the pull arm

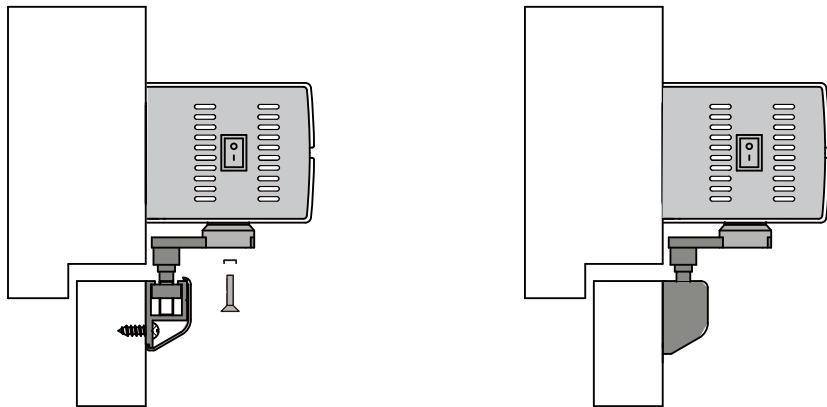

INSTALLATION MANUAL

3.8 Connect the operation system and the push arm

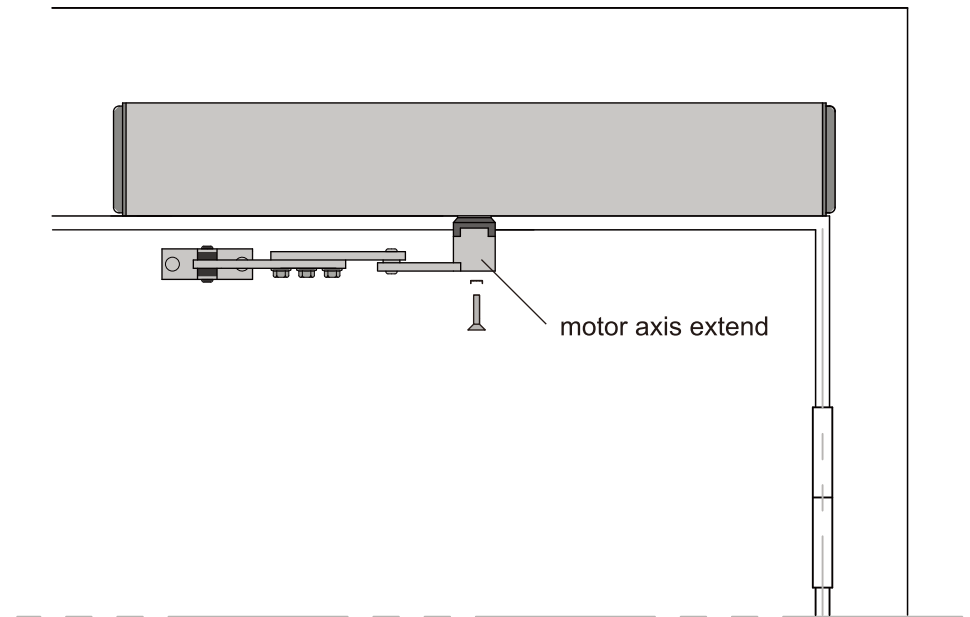

INSTALLATION MANUAL

Electrical connection

power cable

fuse 3A

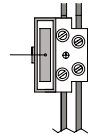

supply power 110~220V

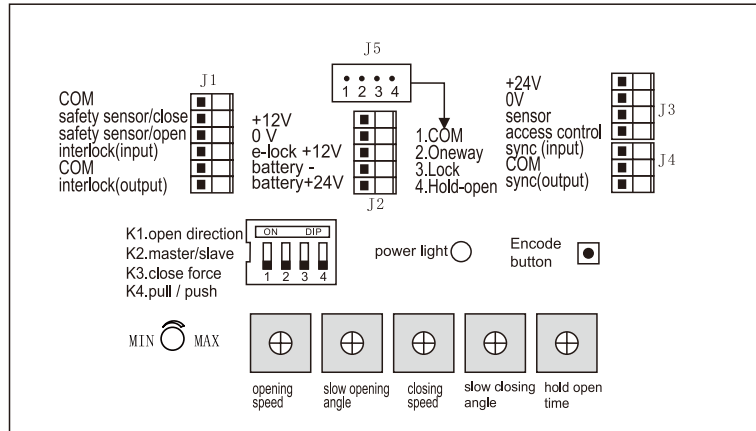

Safety sensor

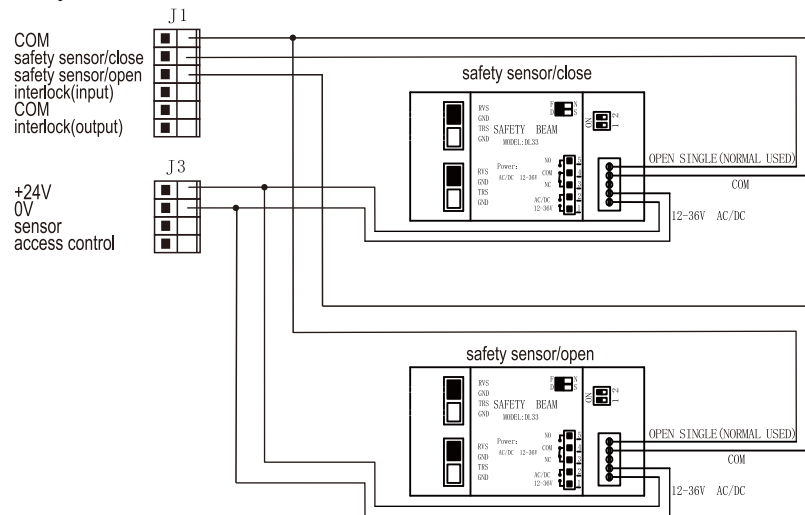

For safety, please connect the connection in J3 with 24V or J2 with 12V.
 When the door is closing, the safety beam/close work, the door will oper again.
 When the door open the safety beam/open work the door will stopped.
 Remake: The output power of 12V should less than 10W.

INSTALLATION MANUAL

Sensor & access control

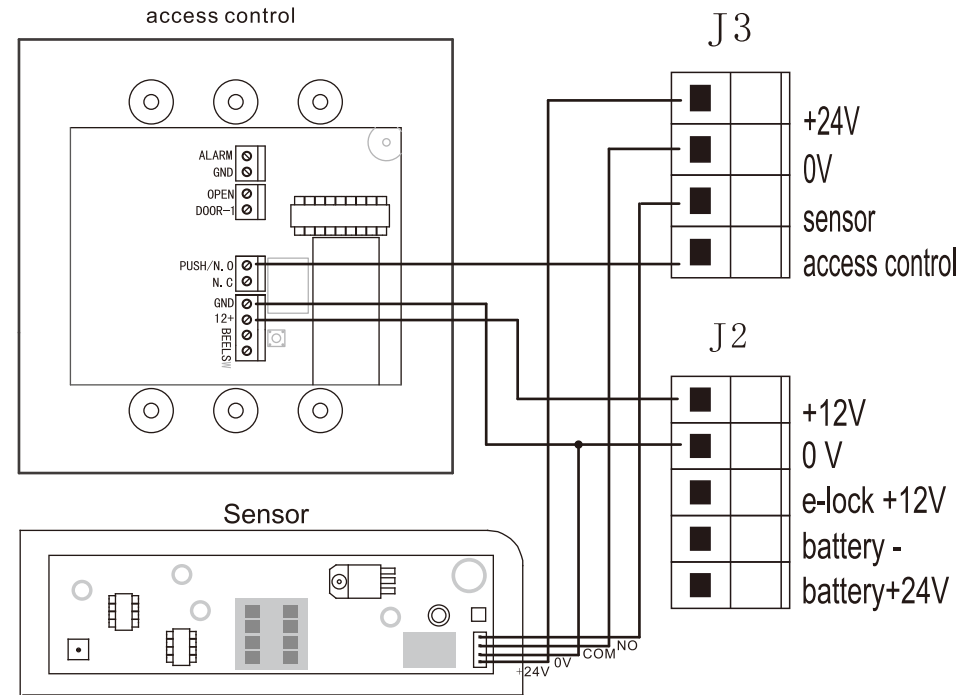

Remake: The output power of 12V should less than 10W.

Electric lock (Automatic lock)

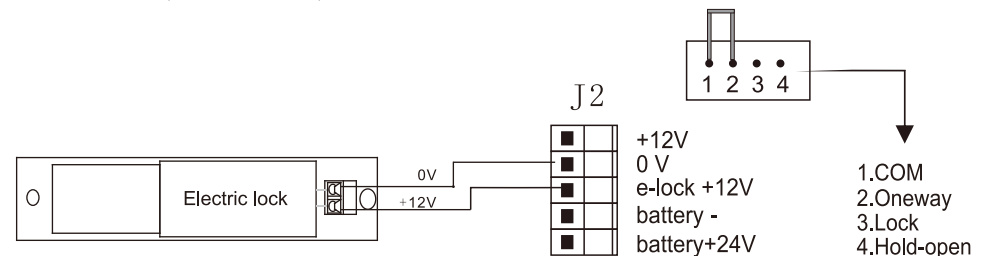

Note: The power supply voltage is 12V, the working current of the electric lock is less than 200mA, and the starting power is less than 800mA.

INSTALLATION MANUAL

Electric lock (Remote control lock)

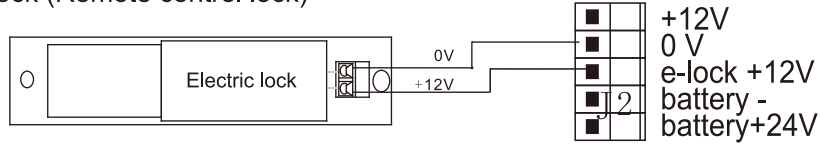

Note: The power supply voltage is 12V, the working current of the electric lock is less than 200mA, and the starting power is less than 800mA.

Backup battery

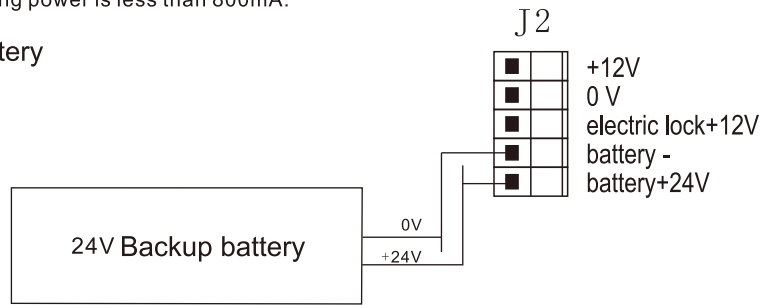

When the backup battery is directly connected to the controller for charging, the charging current must not be greater than 500mA.

Port voltage "battery+" is 27V

Double-door synchronous



Controller A

Controller B

*When double opening/open first and close second is master door, close first and open second is slave door; Master door turn K2 down, slave door turn K2 up.

*Sensors and access control system are connected with the master door controller.

Interlock



Controller A

Controller B

Note: Two doors share same sensor or same signal source, both doors may hold open, in this case, exchange two signal wires of the sensor which is connected with the same controller, it doesn't matter controller A or B.

INSTALLATION MANUAL

optional: Functional key switch

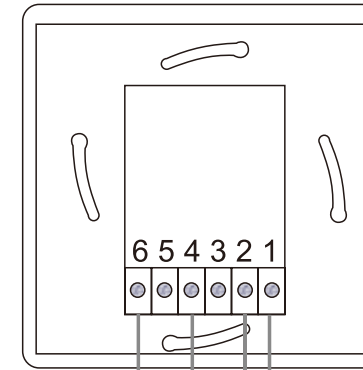

COM
Oneway
Lock
Hold-open

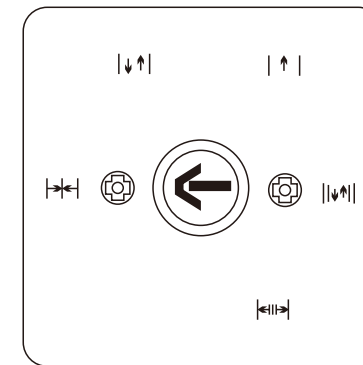

Lock
Automatic
Oneway
Half-open(ignore it)
Hold-open

When the key switch is set in Oneway status, the sensor signal is shielded, But the access control system works normally.

INSTALLATION MANUAL

Optional: remote control

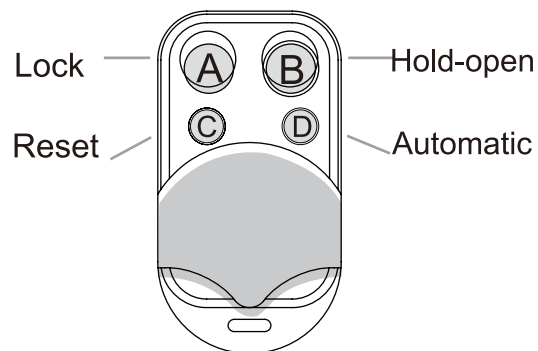

Encode remote control with the door controller:

1. Delete all: long press the button "Encode" until the sound of buzzer disappears, loosen the button.
2. Encoding: long press the button "Encode", the buzzer sounds. Then press any button of the remote control, the buzzer stops sounding which means encoding successfully.
When use the remote control, the buzzer sounds for 2 seconds.
3. Note: when use the remote control, if the buzzer udeep" twice, it means encoding failed, so please repeat above step 2.
4. Press button "automatic" one time, the door wil open and dose one time. One controller can be connected with remote control not more than 10pcs .

INSTALLATION MANUAL

Parameters adjustment

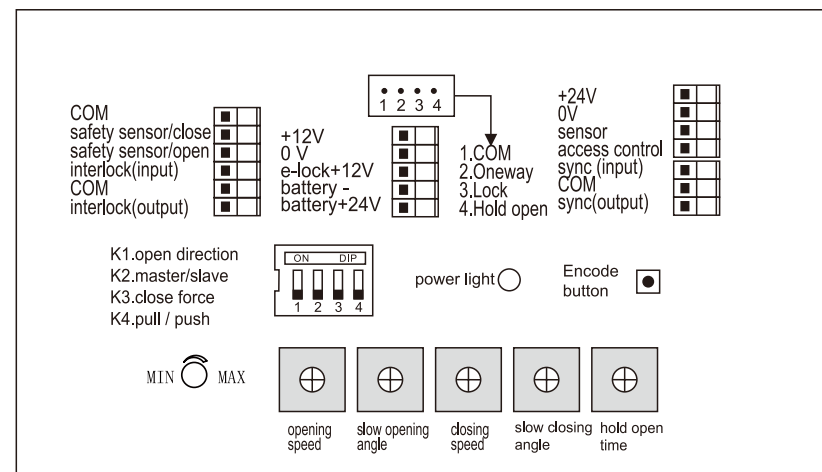

1. Set the DIP switch(K1-K4): after setting, power off and restart.

- K1: Set opening direction: power on, the door goes to closing direction, if not,change the switch position.
- K2: Set master/slave door: when double-door synchronous, master door turn K2 down (OFF), slave door turn K2 up(ON).
- K3: Set closing force: no closing force, turn K3 down(OFF), want closing force, turn K3 up (ON).
- K4: Choose pull arm or push arm: pull arm, turn K4 down(OFF), push arm, turn K4 up (ON),

2. User adjustment:

- | | |
|----------------------|--------------------------------|
| 1.Opening speed | turn clockwise, speed increase |
| 2.Slow opening angle | turn clockwise, angle bigger |
| 3.Closing speed | turn clockwise, speed increase |
| 4.Slow closing angle | turn clockwise, angle bigger |
| 5.Hold-open time | turn clockwise, time longer |

Turn anticlockwise, it is decrease.